

Characteristics

- Rated operating distance 0.4 mm, allows flush mounting
- Double DC three-pole, push-pull output (plus- and minus-switching)
- High geometrical resolution capacity (module ≥ 0.7)
- Detection of approaching or passing soft iron edges

Dimensions

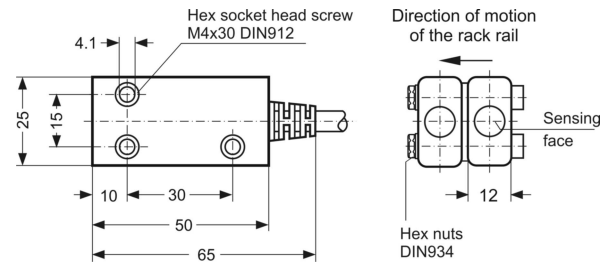

Technical Data

(Unless otherwise specified $U_B = 24\text{ V}$, $T_U \approx 23\text{ }^\circ\text{C}$, and $I_L = 0$)

Rated operating distance s_n	0.4 mm
for rack rail as specified in the mounting instructions	
Rated operating distance s_n	0.2 mm
for very little tooth depths	
Duty cycle v_T	$0.5 (1 \pm 25\%)$
Phase shift ϕ	$90^\circ (\pm 45^\circ)$
Operating voltage U_B	10 ... 24 ... 30 VDC
Permissible ripple voltage	10 %
Current consumption without load	$\leq 25\text{ mA}$
Maximum current output	$\leq 25\text{ mA}$
Voltage drop ($I_L = 0$)	$\leq 1.5\text{ V}$
Voltage drop ($I_L = 25\text{ mA}$)	$\leq 10\text{ V}$
Output	push-pull, short-circuit protection $\leq 20\text{ s}$
Operating frequency f	0 ... 10 kHz
Ambient temperature range T_U	$-25 \dots +75\text{ }^\circ\text{C}$
Reverse voltage protection	yes
Connection	lead connection, LiYY 3 x 0.34 mm ²
Maximum lead length for 10 kHz	15 m
Weight	90 g + weight of the lead
Design	50 x 25 x 12 mm
Housing material / sensing face	aluminium / brass
Protection rating according to EN 60529	IP 67

Mounting Instructions

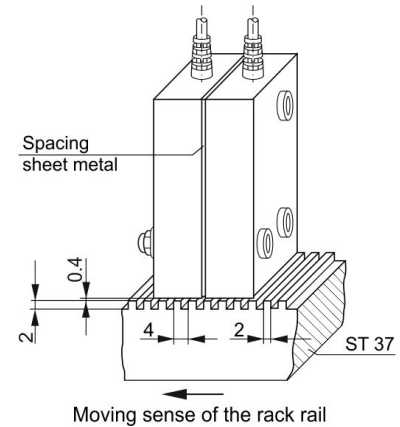

Pulse diagram

Rated operating distance 0.4 mm with rack rail and moving sense as specified in the mounting instructions.

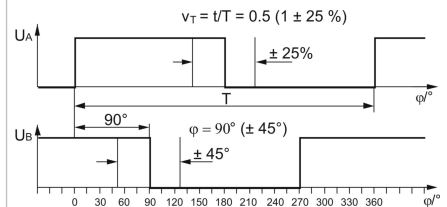

Duty cycle v_T and phase shift ϕ of the output signals depend directly on:

- the direction of motion of the rack rail
- the switching distance
- the ratio tooth - gap
- the material of the rack rail

Deviation from the rack rail specification can change the technical data.

Notes

The sensors were optimised for the rack rail as specified in figure "Mounting Instructions", but may also be used for rack rails with smaller and larger tooth depth. A precise vertical alignment of the housing to the tooth flanks is necessary for mounting. The switching point is not in the geometric axis of the magneto-resistive switches. Keep away metal cuttings from the sensing face. Avoid operation near strong magnetic fields. The distance between the connecting lead and the control leads of the inductive loads should be $\geq 30\text{ cm}$. Use a shielded lead for lead lengths $> 10\text{ m}$. Shield connection only device-sided on L - (0V). Magneto-resistive switches are unsuitable for detecting slots, for axial approach, and for non-magnetic materials.

Certification

Complies with the standard EN 60947-5-2



Safety regulations

Connection, commissioning and maintenance may only be accomplished by specialists or instructed staff.

We are certified according to DIN EN ISO 9001
Subject to technical changes!

Wiring per sensor

For each sensor: DC voltage, three-pole, push-pull output, PVC lead connection

